

**SP-LITE SILICON PYRANOMETER  
INSTRUCTION MANUAL**

**31/05/02**

**COPYRIGHT (c) 1998-2001 CAMPBELL SCIENTIFIC, INC.**



## WARRANTY AND ASSISTANCE

The **SP-LITE SILICON PYRANOMETER** is warranted by CAMPBELL SCIENTIFIC (CANADA) CORP. ("CSC") to be free from defects in materials and workmanship under normal use and service for **twelve (12) months** from date of shipment unless specified otherwise. CSC's obligation under this warranty is limited to repairing or replacing (at CSC's option) defective products. The customer shall assume all costs of removing, reinstalling, and shipping defective products to CSC. CSC will return such products by surface carrier prepaid. This warranty shall not apply to any CSC products which have been subjected to modification, misuse, neglect, accidents of nature, or shipping damage. This warranty is in lieu of all other warranties, expressed or implied, including warranties of merchantability or fitness for a particular purpose. CSC is not liable for special, indirect, incidental, or consequential damages.

Products may not be returned without prior authorization. To obtain a Return Merchandise Authorization (RMA), contact CAMPBELL SCIENTIFIC (CANADA) CORP., at (780) 454-2505. An RMA number will be issued in order to facilitate Repair Personnel in identifying an instrument upon arrival. Please write this number clearly on the outside of the shipping container. Include description of symptoms and all pertinent details.

CAMPBELL SCIENTIFIC (CANADA) CORP. does not accept collect calls.

Non-warranty products returned for repair should be accompanied by a purchase order to cover repair costs.



**CAMPBELL SCIENTIFIC**  
C A N A D A C O R P .

11564 - 149 street - edmonton - alberta - T5M 1W7  
tel 780.454.2505 fax 780.454.2655

[www.campbellsci.ca](http://www.campbellsci.ca)



# ***SP-LITE Table of Contents***

---

<b>1. General Description</b> .....	<b>1</b>
1.1 Electrical Properties.....	1
1.2 Spectral Properties.....	2
1.3 Directional/Cosine Response.....	3
<b>2. Sensor Specifications</b> .....	<b>4</b>
<b>3. Installing the SP-LITE</b> .....	<b>5</b>
<b>4. Wiring</b> .....	<b>7</b>
<b>5. Datalogger Programming</b> .....	<b>7</b>
5.1 Datalogger Input Range Codes.....	8
5.2 Calibration Factor and Multiplier.....	8
5.3 Program Example 1, Average Solar Radiation.....	8
5.4 Program Example 2, Total Solar Radiation.....	10
5.4.1 Output Format Considerations.....	10
<b>6. Maintenance</b> .....	<b>12</b>
6.1 Calibration.....	12
<b>7. Troubleshooting</b> .....	<b>12</b>
7.1 Pyranometer produces no apparent output.....	12
7.2 Readings are not as expected.....	12

## ***Figures***

1. SP-LITE Sensor without Leveling Fixture.....	1
2. SP-LITE Electrical Circuit.....	2
3. Spectral Sensitivity of Pyranometers Compared with Solar Radiation .....	2
4. Cosine Response of a Typical SP-LITE Pyranometer .....	3
5. Dimensions of SP-LITE with Leveling Device.....	4
6. 015 Mounting Arm.....	5
7. 025 STAND and 019 Crossarm.....	6
8. SP-LITE to Datalogger Connections.....	7

## ***Tables***

1. Datalogger Connections for Differential Measurement.....	7
2. Datalogger Connections for Single-Ended Measurement.....	7
3. Multipliers Required for Flux Density and Total Fluxes.....	8



# SP-LITE Silicon Pyranometer

---

*The SP-LITE measures incoming solar radiation (sun plus sky radiation) with a photodiode detector. Output from the photodiode is a current, which is converted to voltage by an internal shunt resistor. The SP-LITE can be used in solar energy applications such as plant growth, thermal convection and evapotranspiration.*

## 1. General Description



FIGURE 1. SP-LITE Sensor without Leveling Fixture

The SP-LITE is used for measuring solar radiation. It measures the solar energy received from the entire hemisphere – i.e. 180° field of view. The output is expressed in Watts per square meter ( $W m^2$ ).

The SP-LITE is designed for continuous outside use, and its calibration is valid only for unshaded natural daylight – not for artificial light. It is most usually used to measure solar radiation being received on the horizontal plane. However, the SP-LITE can, if required, be used in an inverted or tilted position.

### 1.1 Electrical Properties

The SP-LITE consists of a photodiode complete with housing and cable. The circuit includes a shunt resistor for the photodiode in order to generate a voltage output. The electrical specification of the sensor is determined by the characteristics of the photodiode and resistor. The electrical circuit of the pyranometer is shown in Figure 2, below.

The electrical sensitivity of the photodiode changes with temperature. A nominal value for this change is 0.2% change per °C. Calibration is carried out at 20 °C.

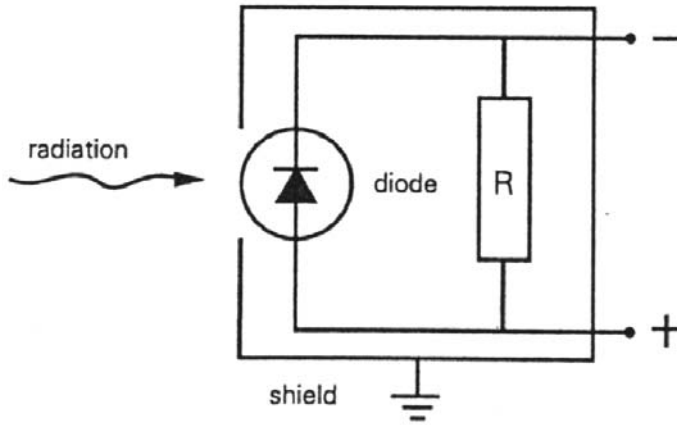

FIGURE 2. SP-LITE Electrical Circuit

## 1.2 Spectral Properties

The spectral properties of the SP-LITE are mainly determined by the spectral response of the photodiode, which is shown in Figure 3, below.

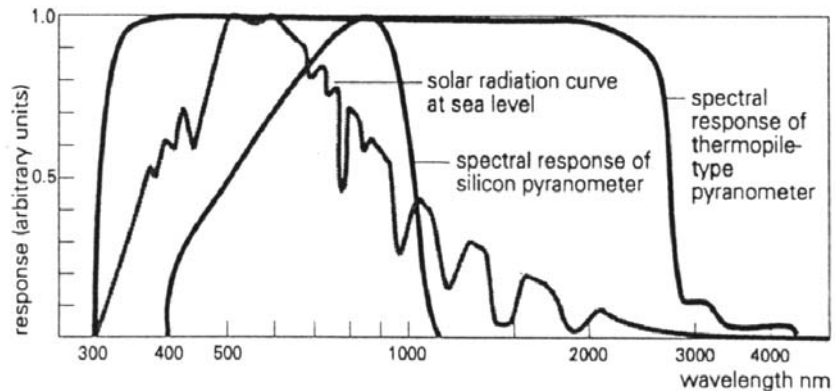

FIGURE 3. Spectral Sensitivity of Pyranometers Compared with Solar Radiation

The SP-LITE is calibrated for solar radiation under clear sky conditions. The spectrum for these conditions, at sea level, is also shown in Figure 3.

Unfortunately, however, the actual solar spectrum varies as a function of cloud cover, season and solar elevation. Since the pyranometer does not have a flat sensitivity across the whole solar spectrum, the accuracy of its response will vary. However, the error range across the whole spectrum has been proven to be small. The maximum total estimated error will only be in the region of  $\pm 5$  percent when compared to the calibration conditions.



Both the spectral sensitivity and the photodiode sensitivity of the SP-LITE will change with temperature, and the separate effect of each of these changes cannot be easily determined.

### 1.3 Directional/Cosine Response

A perfect cosine response will show maximum sensitivity at an angle of incidence of zero degrees (perpendicular to the sensor surface) and zero sensitivity at an angle of incidence of 90 degrees (radiation passing over the sensor surface). At any angle between 0 and 90 degrees the sensitivity should be proportional to the cosine of the angle of incidence.

Figure 4 shows the behavior of a typical SP-LITE. The vertical axis shows the deviation from ideal behavior, expressed in percentage deviation from the ideal value.

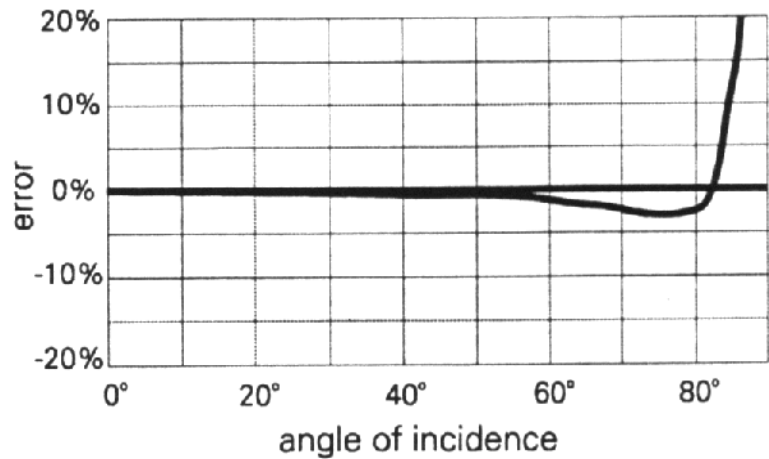

FIGURE 4. Cosine Response of a Typical SP-LITE Pyranometer

In Figure 4, 0 degrees zenith angle equals 90 degrees angle of incidence. The vertical axis shows the percentage deviation from ideal cosine behavior.

## 2. Sensor Specifications

### Electrical

Nominal Impedance:	<50 $\Omega$
Response Time:	<1 second
Sensitivity:	(see Certificate of Calibration that was shipped with sensor)
Expected signal range: (under atmospheric conditions)	0 – 125 mV
Stability:	< $\pm$ 2% per year
Non-linearity:	< $\pm$ 1% up to 1000 W m <sup>-2</sup>
Temperature dependence of sensitivity:	< $\pm$ 0.15% /°C

### Spectral

Spectral range:	400 to 1100 nm
Detector type:	BPW 34

### Directional

Cosine corrected between 80° angle of incidence, error:	within $\pm$ 10%
Cosine errors averaged over opposite azimuth error (at 60° angle of incidence):	within $\pm$ 10%
Tilt response:	zero error

### Mechanical

Housing material:	Anodized aluminum
Cable material:	Polyurethane
Weight:	110 g
Cable length:	5 m (can be extended up to 100 m)
Physical Dimensions:	See Figure 5

### Environmental

Working temperature:	-30 to +70°C
----------------------	--------------

### Dimensions

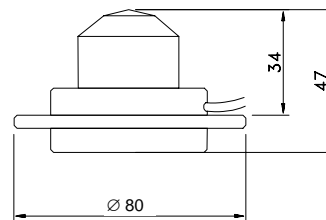

DIMENSIONS IN MM

FIGURE 5. Dimensions of SP-LITE with Leveling Device

### 3. Installing the SP-LITE

The SP-LITE and CLF1 base/leveling fixture are attached to a tripod or tower using one of two mounting configurations (see Figures 6 - 7).

Mount the sensor on the mounting arm so that no shadow will be cast on it at any time of day, at any time of year, from obstructions such as trees, buildings or the mast or structure on which it is mounted. In the northern hemisphere the instrument is normally oriented towards the South to avoid potential problems from shading.

---

**NOTE**

The SP-LITE will only perform to specification under clear-sky conditions. It must not be mounted where it is subject to shade, beneath structures or beneath a plant canopy.

---

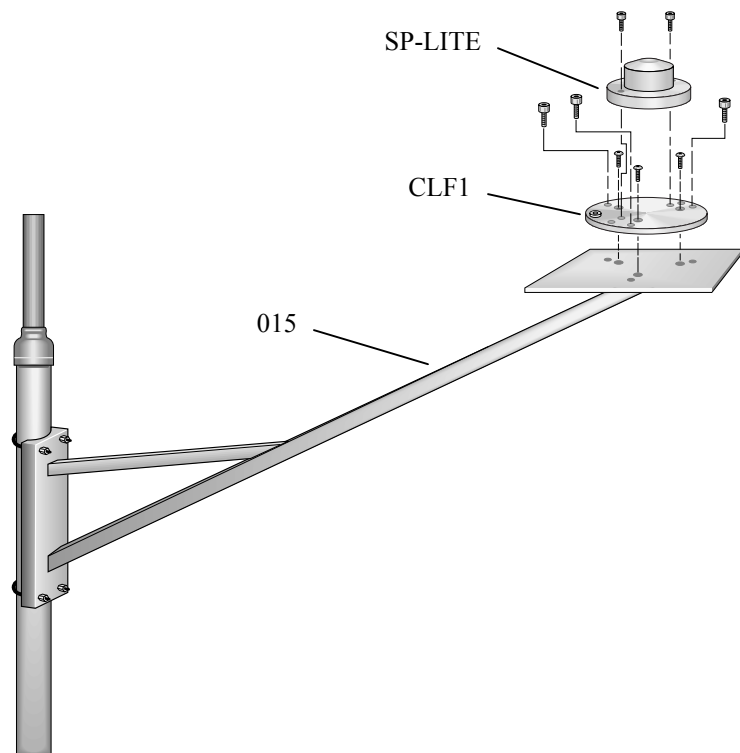

FIGURE 6. 015 Mounting Arm

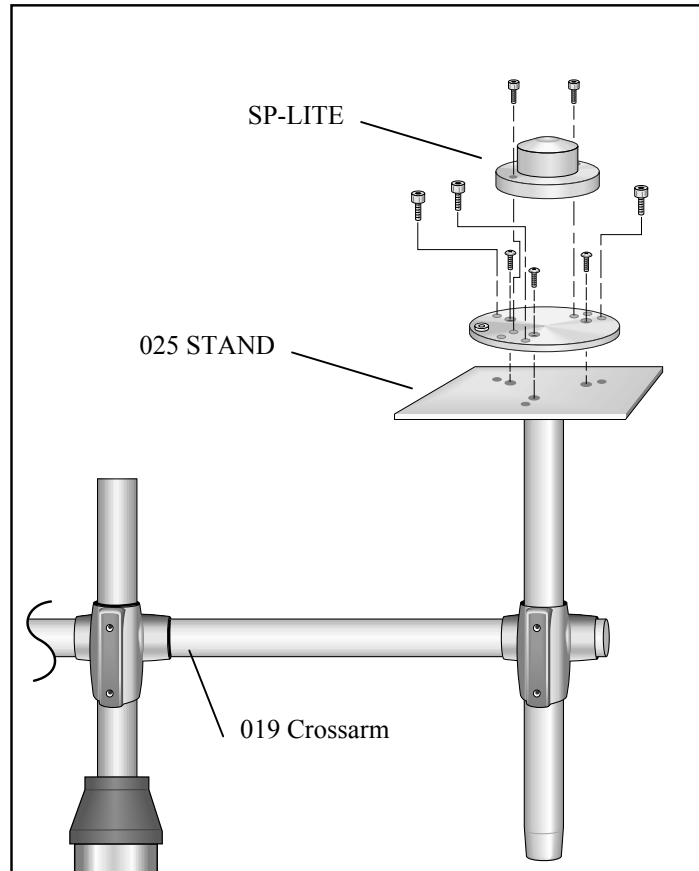

FIGURE 7. 025 STAND and 019 Crossarm

Mount the sensor on the mounting arm at a height of at least 1.5 m above the ground surface to minimize shading effects. The CLF1 mounting bracket has a built-in bubble level that is used to mount the SP-LITE to the 025 STAND or 015 ARM. Mount and adjust the SP-LITE as follows:

1. Attach the mounting arm to the tripod or tower at the required height.
2. Loosely attach the CLF1 Kipp & Zonen Base and Leveling fixture to the mounting arm using the three mounting screws provided with the mounting arm (025 STAND or 015 ARM).
3. Level the CLF1 by adjusting the three outside leveling screws as required to center the bubble in the level. Tighten the three mounting screws.
4. Attach the SP-LITE to the CLF1 using the two screws provided.

## 4. Wiring

The SP-LITE can be measured with a differential or single-ended channel on the datalogger; a differential channel is recommended.

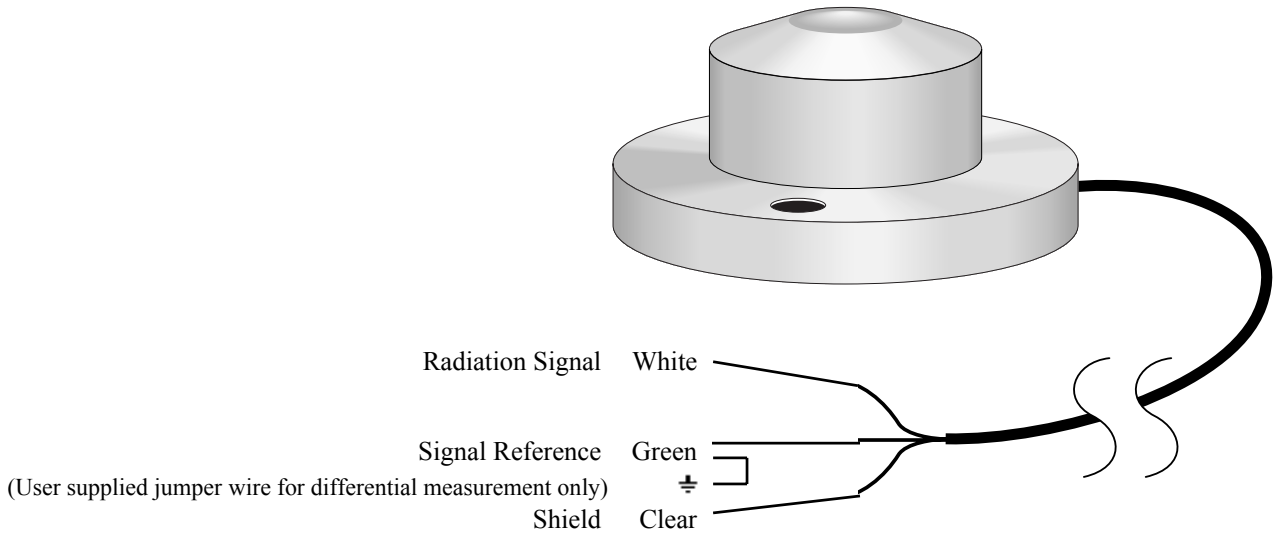

FIGURE 8. SP-LITE to Datalogger Connections

Function	Colour	CR10X,CR510	CR23X	21X/CR7
Radiation Signal	White	Differential H	Differential H	Differential H
Signal Reference	Green	Differential L	Differential L	Differential L
	Jumper to	AG	⊕	⊕
Shield	Clear	G	⊕	⊕

Function	Colour	CR10X,CR510	CR23X	21X/CR7
Radiation Signal	White	S.E. Channel	S.E. Channel	S.E. Channel
Signal Reference	Green	AG	⊕	⊕
Shield	Clear	G	⊕	⊕

## 5. Datalogger Programming

The SP-LITE outputs a low-level voltage ranging from 0 to a maximum of about 15mV. A differential voltage measurement (Instruction 2) is recommended because it has better noise rejection than a single-ended measurement. If a differential channel is not available, a single-ended measurement (Instruction 1) can be used. The acceptability of a single-ended measurement can be determined by simply comparing the results of single-ended and differential measurements made under the same conditions.

## 5.1 Datalogger Input Range Codes

Normally the 500 mV range for the 21X and CR7, the 250 mV range for the CR10(X) and CR500/CR510, and the 200 mV range for the CR23X are suitable.

The parameter code for the input range also specifies the measurement integration time. The slow or 60 Hz rejection integration gives a more noise-free reading. A fast integration takes less power and allows for faster throughput.

## 5.2 Calibration Factor and Multiplier

All SP-LITE sensors have a sensitivity (calibration factor) listed on the calibration sheet (see Appendix A for example). Solar radiation can be reported as an average flux density ( $W\ m^{-2}$ ) or daily total flux density ( $MJ\ m^{-2}$ ). The appropriate multipliers for the measurement instruction are listed in Table 3. Programming examples are given for both average and daily total solar radiation.

Units	Multipliers	Output Processing
$MJ\ m^{-2}$	$t*[1/(1000*C)]$	(P72 total fluxes)
$KJ\ m^{-2}$	$t*(1/C)$	(P72 total fluxes)
$W\ m^{-2}$	$1000/C$	(P71 flux density)
$KW\ m^{-2}$	$1/C$	(P71 flux density)
$cal\ cm^{-2}$	$t*0.0239*(1/C)$	(P72 total fluxes)
$cal\ cm^{-2}\ min^{-1}$	$1.434*(1/C)$	(P71 flux density)

t = the datalogger program execution interval in seconds  
 C = Sensitivity (calibration factor with units of  $\mu V/W/m^2$ )

## 5.3 Program Example 1, Average Solar Radiation

The examples below give the appropriate datalogger code for the CR10X datalogger, using either Instruction 2 (differential) or Instruction 1 (single-ended).

Example 1 shows the program instructions used to measure the signal from the SP-LITE. A thirty-minute average is calculated and stored in final storage.

### Wiring for Example 1

Colour	Function	Example CR10X Program Channels Used
White	Radiation Signal	1H
Green	Signal Reference	1L
Jumpered to		AG
Clear	Shield	G

**EXAMPLE 1. Sample Instructions used to Measure an Average Flux with a CR10X**

```

;{CR10X}
;
;*Table 1 Program
  01: 10      Execution Interval (seconds)

01: Volt (Diff) (P2)
  1: 1      Reps
  2: 24**   ± 250 mV 60 Hz Rejection Range
  3: 1*     DIFF Channel
  4: 1*     Loc [ W_m2   ]
  5: 12.3457*** Mult
  6: 0      Offset

;Set negative values to zero.
;
02: If (X<=>F) (P89)
  1: 1*     X Loc [ W_m2   ]
  2: 4      <
  3: 0      F
  4: 30     Then Do

03: Z=F (P30)
  1: 0      F
  2: 0      Exponent of 10
  3: 1*     Z Loc [ W_m2   ]

04: End (P95)

05: If time is (P92)
  1: 0      Minutes (Seconds --) into a
  2: 30     Interval (same units as above)
  3: 10     Set Output Flag High (Flag 0)

06: Real Time (P77)
  1: 0220   Day,Hour/Minute (midnight = 2400)

07: Average (P71)
  1: 1      Reps
  2: 1*     Loc [ W_m2   ]

-Input Locations-
1 W_m2

```

\* Proper entries will vary with program and input channel assignments.

\*\* The 250 mV range for CR10(X) and CR500/CR510, the 200 mV range for the CR23X, and the 500 mV range for the 21X and CR7.

\*\*\* See Table 3 for alternative multipliers.

## 5.4 Program Example 2, Total Solar Radiation

In Example 2 a daily total flux density is found. This total flux density is in MJ m<sup>-2</sup> day<sup>-1</sup>. Negative values are set to zero before they are added to the running total.

### 5.4.1 Output Format Considerations

If the solar radiation is totalized in units of kJ m<sup>-2</sup>, there is a possibility of overranging the output limits. The largest number that the datalogger can output to final storage is 6999 in low resolution and 99999 in high resolution (Instruction 78, Set Resolution).

Assume that the daily total flux density is desired in kJ m<sup>-2</sup>. Assume an irradiance of 0.5 kW m<sup>-2</sup>, the maximum low resolution output limit will be exceeded in just under four hours. This value was found by taking the maximum flux density the datalogger can record in low resolution and dividing by the total hourly flux density.

$$3.9 \text{ hr} = \frac{6999 \text{ kJ m}^{-2}}{(0.5 \text{ kJ m}^{-2} \text{ s}^{-1})(3600 \text{ s hr}^{-1})} \quad (1)$$

To circumvent this limitation, record an average flux (see Example 1). Then, during post processing, multiply the average flux by the number of seconds in the output interval to arrive at a output interval flux density. Sum the output interval totals over a day to find a daily total flux density.

Another alternative is to record total flux using the high resolution format (Instruction 78, see Datalogger manuals for details). The disadvantage of the high resolution format is that it requires four bytes of memory per data point, consuming twice as much memory as low resolution.

#### Wiring for Example 2

Colour	Function	Example CR10X Program Channels Used
White	Radiation Signal	S.E. Channel 1
Green	Signal Reference	AG
Clear	Shield	G



**EXAMPLE 2. Sample Instructions used to Measure a Daily Total Flux Density with a CR10X**

```
;{CR10X}
;
;*Table 1 Program
 01: 10      Execution Interval (seconds)

01: Volt (SE) (P1)
  1: 1      Reps
  2: 24**   ± 250 mV 60 Hz Rejection Range
  3: 1*     SE Channel
  4: 1*     Loc [ MJ_m2  ]
  5: .00012*** Mult
  6: 0     Offset

;Set negative values to zero.
;
02: If (X<=>F) (P89)
  1: 1*     X Loc [ MJ_m2  ]
  2: 4      <
  3: 0      F
  4: 30     Then Do

03: Z=F (P30)
  1: 0      F
  2: 0      Exponent of 10
  3: 1*     Z Loc [ MJ_m2  ]

04: End (P95)

05: If time is (P92)
  1: 0      Minutes (Seconds --) into a
  2: 1440   Interval (same units as above)
  3: 10     Set Output Flag High (Flag 0)

06: Real Time (P77)
  1: 0220   Day,Hour/Minute (midnight = 2400)

07: Totalize (P72)
  1: 1      Reps
  2: 1*     Loc [ MJ_m2  ]

-Input Locations-
1 MJ_m2

*   Proper entries will vary with program and input channel assignments.
**  The 250 mV range for CR10(X) and CR500/CR510, the 200 mV range for the CR23X,
    and the 500 mV range for the 21X and CR7.
*** See Table 3 for alternative multipliers.
```

## 6. Maintenance

The SP-LITE is an ‘all weather’ instrument and is very stable, but should be handled with care. It requires little periodic maintenance, apart from cleaning the sensor surfaces carefully with a soft cloth using water or alcohol.

### 6.1 Calibration

It is recommended that the SP-LITE is checked, and re-calibrated if necessary, every two years. The calibration can be checked by running the SP-LITE in parallel with a reference sensor for at least two sunny days, and then comparing the daily readings. The reference sensor should either be a higher standard pyranometer, or an SP-LITE that is kept stored and used solely for this purpose. If results differ by more than 5 percent, the sensor should be returned for re-calibration. Please contact Campbell Scientific for further details.

## 7. Troubleshooting

### 7.1 Pyranometer produces no apparent output

If your pyranometer does not appear to be working at all, do the following checks:

- With the SP-LITE disconnected from the datalogger, connect a volt meter to the white (+) and green (-) wires. The voltage range should be ~ 0-120 mV for 0-1500 W m<sup>-2</sup> radiation.
- If this appears to produce no results, measure the impedance of the sensor across the white and green wires. The impedance reading should be close to 50W. If it is less than 5W, a short circuit is indicated. If it is ‘infinite’, the sensor is damaged, or the cable is broken.

### 7.2 Readings are not as expected

- Under full sunlight the expected radiation value is about 1000 W m<sup>-2</sup>.
- Verify that the multiplier parameter in the measurement instruction is correct for the desired units (e.g., W m<sup>-2</sup>, see Section 5 above).
- Check the datalogger program for errors.

If you cannot resolve your problems, please contact Campbell Scientific for further advice.

# APPENDIX A



**Kipp &  
Zonen**

ANNIVERSARY

**Kipp & Zonen B.V.**  
Röntgenweg 1 2624 BD Delft  
P.O. box 507 2600 AM Delft  
The Netherlands  
Tel: +31-15-2698000  
Fax: +31-15-2620351  
Email: [info.holland@kippzonen.com](mailto:info.holland@kippzonen.com)  
Website: <http://www.kippzonen.com>

## SAMPLE CERTIFICATE OF CALIBRATION

Instrument type:	SP LITE	
Serial number:	010978	
Reference sensor:	PROTO1	
→ Sensitivity:	81 $\mu\text{V}/\text{W}/\text{m}^2$	<b>Use this in determining the multiplier</b>
Date:	22-01-2001	
Performed by:	F.de Wit	

The primary standard for pyranometers is the World Radiometric Reference. The SP LITE pyranometers are calibrated against a Kipp & Zonen secondary standard under natural sunlight under clear sky conditions. Further reference conditions are as follows: temperature 20 degrees Celsius, irradiance 500 Watts per square metre.

### NOTICE:

Read the instruction manual before using this sensor.  
It is recommended that sensors be recalibrated every two years.